

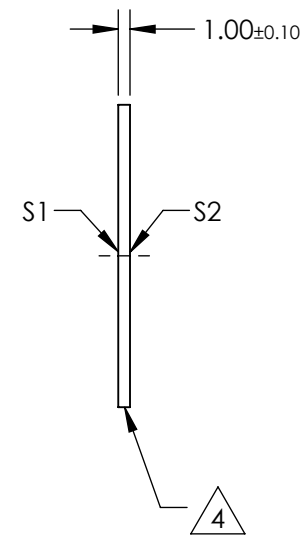

NOTES:

1. SUBSTRATE:
VACUUM UV GRADE CaF₂
2. SURFACE S2 TO BE PARALLEL WITH S1 TO < 1 ARCMIN
3. COATING (APPLY ACROSS CLEAR APERTURE)
S1 & S2: NONE
4. FINE GRIND SURFACE

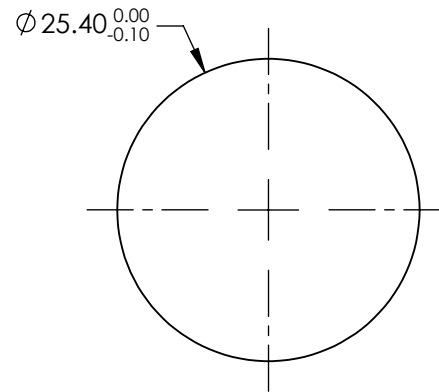
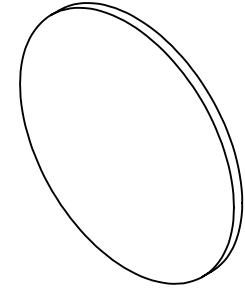

**FOR INFORMATION ONLY:
DO NOT MANUFACTURE
PARTS TO THIS DRAWING**

SPECIFICATIONS SUBJECT TO CHANGE WITHOUT NOTICE
DIMENSIONS ARE FOR REFERENCE ONLY

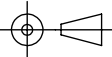
	S1	S2	 Edmund Optics®				
SHAPE	PLANO	PLANO					
SURFACE FLATNESS	λ	λ	THIRD ANGLE PROJECTION 	TITLE		25.4mm Dia., 1mm Thick Uncoated, Calcium Fluoride Window	
SURFACE QUALITY	40-20	40-20		ALL DIMS IN	mm	DWG NO	22457
CLEAR APERTURE	Ø22.86	Ø22.86					SHEET 1 OF 1
BEVEL	PROTECTIVE AS NEEDED	PROTECTIVE AS NEEDED					