

**FOR INFORMATION ONLY:
DO NOT MANUFACTURE
PARTS TO THIS DRAWING**

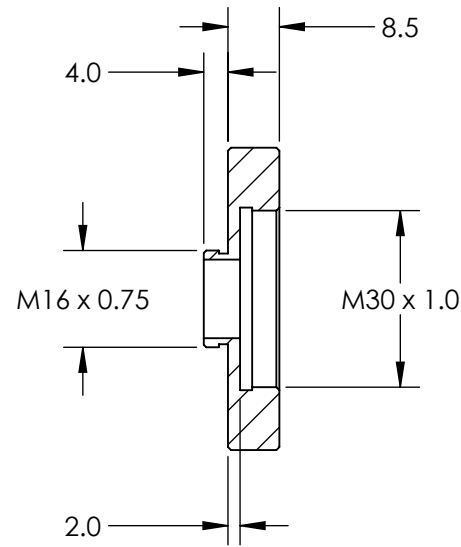
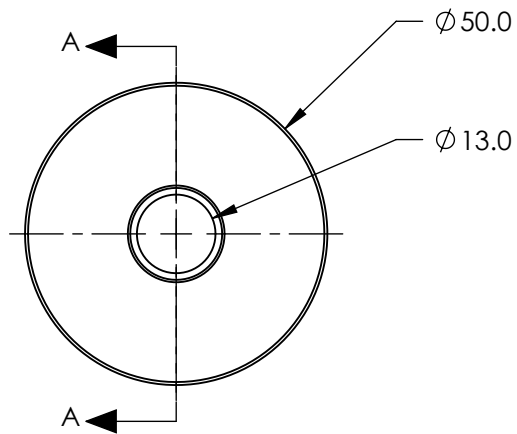
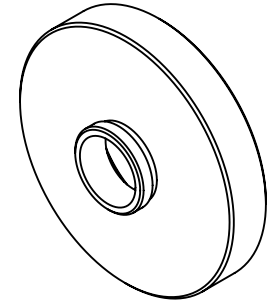

SECTION A-A

SPECIFICATIONS SUBJECT TO CHANGE WITHOUT NOTICE
DIMENSIONS ARE FOR REFERENCE ONLY

EO® Edmund Optics®

REV. A	VALUE	THIRD ANGLE PROJECTION	TITLE	FEMALE M30 x 1.0 TO M16 x 0.75 ADAPTER
CONSTRUCTION	ALUMINUM		DWG NO	35477
COATING TYPE	BLACK ANODIZED		ALL DIMS IN	mm