

NOTES:

1. SUBSTRATE:
ELEMENT A: N-BK7 517/642
ELEMENT B: N-SF5 673/322
2. ROHS COMPLIANT
3. CENTERING TOLERANCE (AT 587.6nm):
BEAM DEVIATION (HALF ANGLE): <1 ARCMIN
4. COATING (APPLY ACROSS COATING APERTURE)
S1 & S4: VIS 0°
R(AVG) ≤ 0.4% FROM 425 - 675nm @ 0° AOI
S2 & S3: NONE

△5 FINE GRIND SURFACE

6. POWER, IRREGULARITY, AND SURFACE QUALITY SPECIFICATIONS APPLY ACROSS CLEAR APERTURE

7. FOCAL LENGTH (EFL): 300.00mm±1%
BACK FOCAL LENGTH (BFL): 290.62mm

8. PROTECTIVE BEVEL AS NEEDED

9. DESIGN WAVELENGTH: 587.6nm

△9 ELEMENTS TO BE CEMENTED WITH NORLAND OPTICAL ADHESIVE NOA61

△10 BLACKENED SURFACE

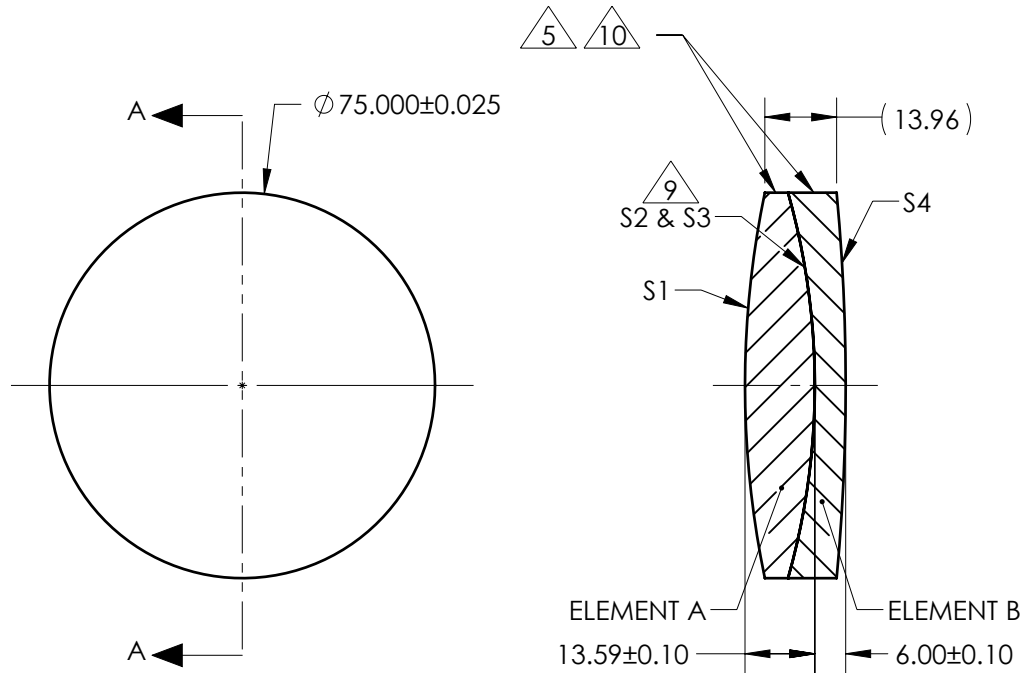

SECTION A-A

**FOR INFORMATION ONLY:
DO NOT MANUFACTURE
PARTS TO THIS DRAWING**

SPECIFICATIONS SUBJECT TO CHANGE WITHOUT NOTICE
DIMENSIONS ARE FOR REFERENCE ONLY

ELEMENT TITLE	SPECIFICATIONS AFTER CEMENTING			
	ELEMENT A		ELEMENT B	
SURFACE	S1	S2	S3	S4
SHAPE	CONVEX	CONVEX	CONCAVE	CONVEX
RADIUS	184.05	137.34	137.34	399.33
SURFACE QUALITY	40 - 20	40 - 20	40 - 20	40 - 20
MIN CLEAR APERTURE	ϕ 73.00	ϕ 73.00	ϕ 73.00	ϕ 73.00
MIN COATING APERTURE	ϕ 74.00	N/A	N/A	ϕ 74.00
POWER AT 632.8nm	3.00 RINGS	8.00 RINGS	8.00 RINGS	3.00 RINGS
IRREGULARITY AT 632.8nm	0.50 RINGS	2.00 RINGS	2.00 RINGS	0.50 RINGS

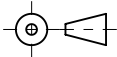
THIRD ANGLE PROJECTION 

ALL DIMS IN mm

EO [®] Edmund Optics [®]

TITLE: 75mm Dia. x 300 mm FL, VIS 0, Inked, Achromatic Lens

DWG NO: 88594INK

SHEET 1 OF 1